

POOLSOLAR

Installation Guide

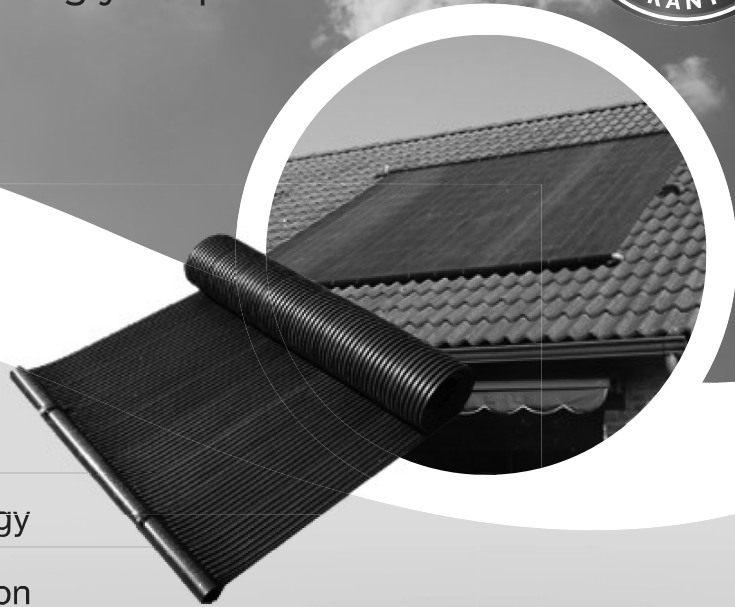

A **FREE** alternative to heating your pool using a Poolsolar System



- ✓ 5 year warranty
- ✓ Utilise the sun's natural energy
- ✓ Extend your swimming season
- ✓ Easy to install on any surface
- ✓ EPDM High quality rubber
- ✓ Maintenance free



Paramount
POOL PRODUCTS
over 40 years service to the industry

Thank you for purchasing Poolsolar. Whether you are building or, already have a pool, the Poolsolar is the ideal way of adding extra FREE heat to your pool when the sun is shining!

This installation manual provides a step by step guide to installing the Poolsolar. Prior to installation, please make sure that you have all the necessary tools, plumbing fittings and pipework etc. see pages 2 & 3. If you have any queries, please contact your dealer who will be able to assist you.

If installing on a rooftop please make sure that adequate safety precautions are in place i.e safety harness, scaffold towers etc. We would advise that a minimum of two people are used to install the solar collector.

Poolsolar should give you years of trouble free heating - Enjoy.

To view this manual in colour, please go www.paramountpools.co.uk where a down load is available.

5 YEAR WARRANTY

Poolsolar warrants the solar collectors to be free from defects in material and workmanship and to perform under normal use and service for five years from the date of purchase receipt, providing that the solar collector has been installed in accordance with Poolsolar installation instructions. The warranty is limited to the original customer purchaser and is not assignable.

Repair: If a defect in materials or workmanship becomes evident during normal use and service within five years, we will supply replacement parts free of charge, within a reasonable time, without transportation costs (limited to United Kingdom).

What is not covered:

- * Poolsolar will not be liable for consequential damages to you home or other equipment, loss of time, inconvenience or loss of use of the solar collector.
- * Poolsolar will not be liable for conditions resulting from a defect in a component or part which is not part of the Poolsolar collector.
- * Poolsolar will not be liable for conditions resulting from any misuse, abuse, negligence, accident, or alteration of the solar collector.
- * Poolsolar will not be liable for conditions resulting, from significant deviation from Poolsolar installation instructions.
- * Poolsolar will not be liable for conditions resulting from fire, lightning, floods, winds, accidents, animal damage or other conditions above our control.

These warranties are the only warranties and it is understood that no other warranties are expressed or implied without otherwise being agreed in writing.

INDEX

Page 2	Site Location
Page 2	Tools & Plumbing Requirements
Page 3	Parts List
Page 4	Installation Guide - Standard Application
Page 7	Alternative Roof Fixing Method
Page 8	Plumbing Connection
Page 10	3-Way Valve Operation
Page 10	Winterisation
Page 11	Solar Control System (Automatic 3-way valve)
Page 14	Booster Pump Installation - Existing Pool
Page 15	Booster Pump Installation - New Pool Construction
Page 16-17.....	Repairing Pool Solar

SITE LOCATION The Poolsolar solar collectors should be positioned facing the sun as much as possible for a maximum efficiency, ideally 30 deg (above horizontal) facing South.

FILTRATION - MAXIMUM WORKING PRESSURE SHOULD NOT BE ABOVE 1.5 BAR (22 PSI)

A solar heat retention cover must be applied to swimming pool overnight and when the pool is not in use to prevent heat loss.

If installing Poolsolar on a ground surface i.e. for small above ground or splasher type pools please be aware that Poolsolar is not designed for heavy foot traffic.

Make sure that all pipework to and from the solar collector can be drained for the winter period.

We would recommend the use of a time clock to automatically turn off the filtration system at night or bypass the solar system. Alternatively, an automatic control system can be installed see page 11.

Please take sufficient safety precautions before working on a roof.

TOOLS AND PLUMBING REQUIREMENTS

Prior to commencing installation we recommend that you have the following tools and accessories available:-

Tools:- Drill / Extruder Gun (for adhesive tubes) / Mini Wallpaper Roller / Screw Drivers / Hacksaw / Knife

Accessories:-

ABS/PVC Glue / 1.5" Pool Plumbing (not domestic waste pipe) / PTFE Tape

Manual or Automatic 3-way Valve

Vacuum Breaker- Air release valve (see page 9, step 12)

Roof Fixing Paste

White Spirit

2000mm x 60mm x 40mm Rigid Plastic Angle (available from your dealer) for support on pitched roof installations see page 2.

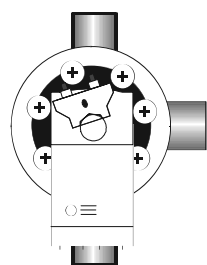
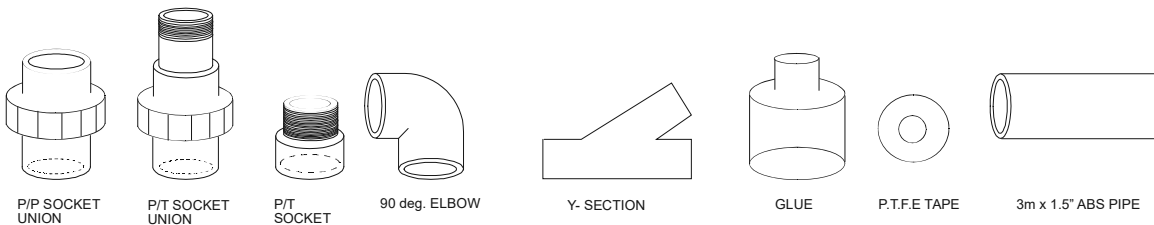

Automatic 3-Way Valve

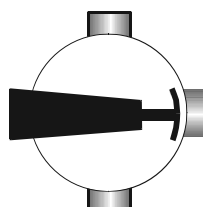

Manual 3-Way Valve

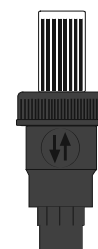

VACUUM BREAKER
(Model may vary)

PARTS LIST

Pool Solar is supplied in a 4 or 5m kit boxes and contains all the necessary components for you to install a solar collector. In addition to this you will require pool plumbing, roof adhesive and roof supports angles.

THE 4m² BOX CONTAINS

- 4 units of solar collectors, each 33cm x 3m (4 m²) (and o-rings)
- 8 metre nylon band to attach the headers and the absorber
- repair set and lubricant
- two adaptors 50 mm in black ABS (C6 and C13)
- two threaded adaptors 1 1/2" in black ABS (C8 and C9)
- two reducing sockets (C12) in black ABS
- one threaded stop 1 1/2" in black ABS
- tie-wraps
- installation guide

THE 5 m² BOX CONTAINS

- 3 units of solar collectors , each 33cm x 5m (5 m²) (and o-rings)
- 10 metre nylon band to attach the headers and the absorber
- repair set and lubricant
- two adaptors 50 mm in black ABS (C6 and C13)
- two threaded adaptors 1 1/2" in black ABS (C8 and C9)
- two reducing sockets (C12) in black ABS
- one threaded stop 1 1/2" in black ABS
- tie-wraps
- installation guide

To install Poolsolar onto a tiled roof you will need to attach L-shaped support angles to support the headers.

Plastic extrusion (H) are 2000 x 60 x 40 mm and are available from your pool dealer.

The L-shaped extrusion is supplied in 2.00 m lengths. Depending on the number of solar matts that you have purchased you will need to apply enough extrusion to support the entire length of the headers (manifolds) top and bottom.

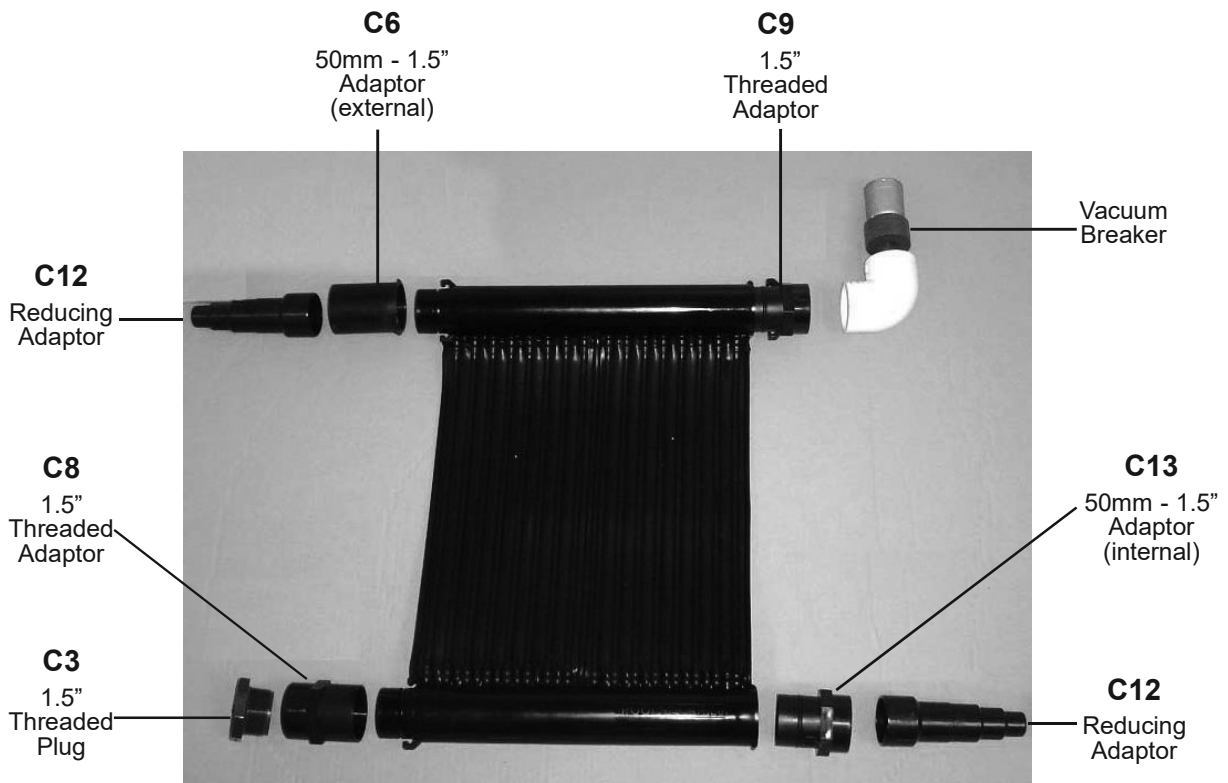
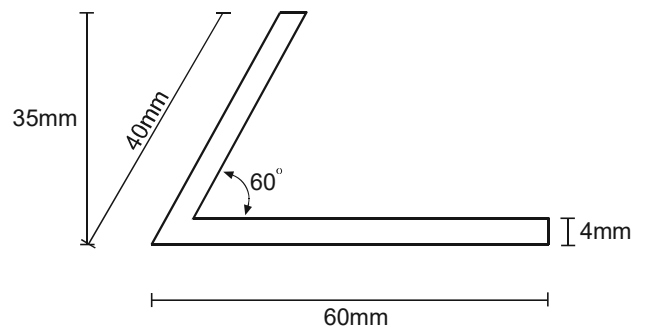

INSTALLATION GUIDE

STEP 1 Remove solar collectors (A) from the box and place side by side in front of you with the narrow part of the headers (B) to the left on a clean, flat surface. The header with the word "POOLSOLAR" must be visible. To check if the matting is the right way up, look at the rubber that connects the absorber tubes together; the material should arch upwards (C).

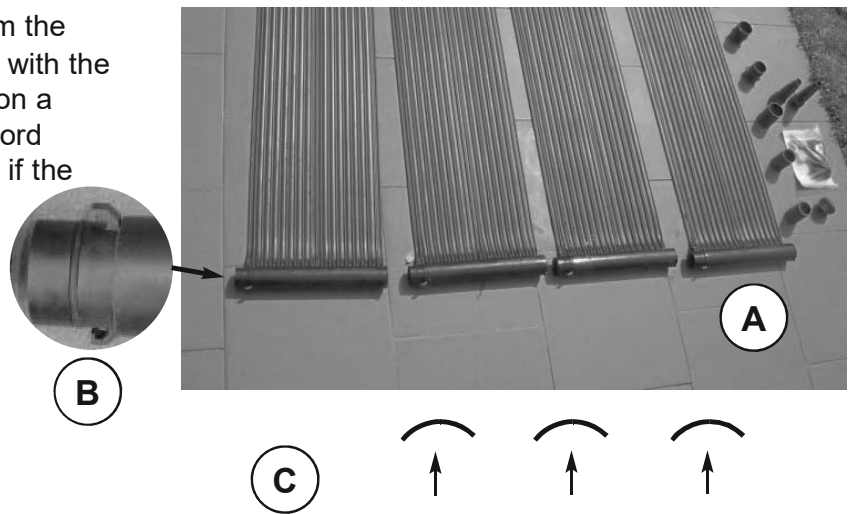

STEP 2 Join the polypropylene headers together applying a liberal amount of lubricant (provided) (D) to the header o-ring. Make sure that the o-ring doesn't bulge out after clicking the headers together. Do not attempt to glue headers together.



STEP 3 Push the rubber edges (E) together so the absorbers (EPDM matting) are united as a whole.

Tip - use a mini wallpaper roller to push the absorbers together!

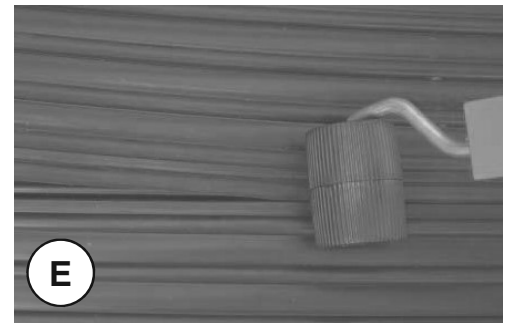

STEP 4 Before applying to the roof, make sure that the Poolsolar is the right way up. Small holes (F) are located along the length of the absorbers to allow rain water to be drained. Make sure that the holes are not blocked especially on a flat roof. Do not use screws in these holes to fix the absorbers.

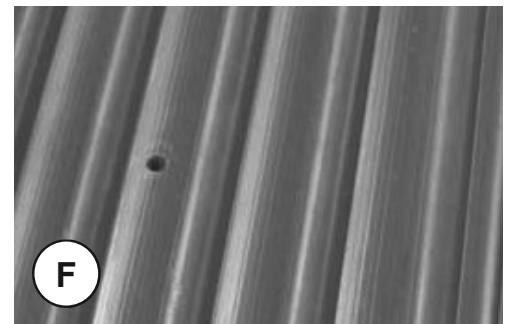

NOTE. Steps 5-10 are for instructions for a tiled pitched roof. If the application is for a flat roof, exactly the same fixing method is used but on a level platform!

STEP 5 Roll up the entire collector (G), starting with the headers showing "POOLSOLAR" (When they are unrolled on the roof you should be able to see the word Poolsolar on the bottom manifolds only - see page 6 (M).



You are now ready to apply the Poolsolar onto roof structure.

*** DO NOT ATTEMPT TO ROLL UP AND INSTALL MORE THAN ONE BOX AT A TIME (3 or 4 Collectors)**

Make sure that where the Poolsolar is to be sited that you are able to attach the supply and return plumbing pipes from the filtration (page 9). Adequate drainage is also required to remove rain water.

IMPORTANT SAFETY NOTICE - It is paramount that adequate safety precautions are taken when installing Poolsolar on a roof structure.

STEP 6 To install Poolsolar onto a tiled roof you will need to attach L-shaped support angles to support the headers see page 2

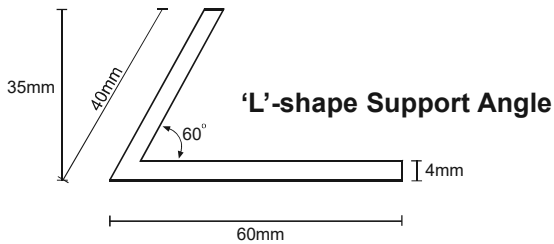

The L-shaped support angle is supplied in 2.00 m lengths. Depending on the number of solar matts that you have purchased, cut and prepare the number of support extrusion required to support 90-100% of the headers that will be located at the top of the roof structure.

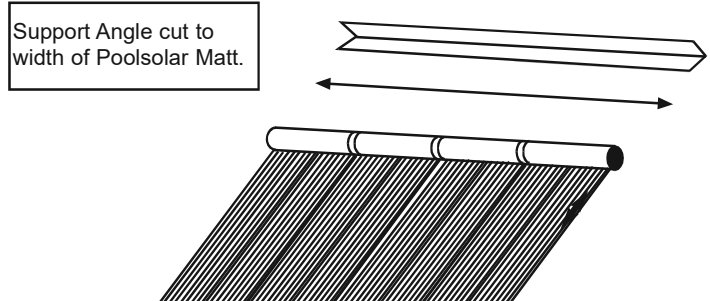

(H) Apply the support angles directly to the roof tiles using liberal amounts of 'roof fixing adhesive paste' (available from your dealer).

Apply the 60mm width of the support angle to the tiles. Prior to applying the adhesive make sure the tiles are dry, clean and dust free. Leave for 24 hours for adhesive to fully cure.

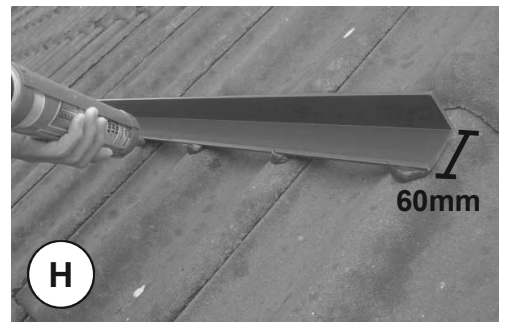

Note: the adhesive is only as good as the surface it is applied to, therefore ensure the surface is free of any loose foreign material.

IF FOR ANY REASON YOU ARE NOT UNABLE TO USE AN ADHESIVE OR THE SUPPORT ANGLE - PLEASE GO TO PAGE 7 FOR ALTERNATIVE FIXING METHOD

STEP 7 Position Poolsolar headers onto support angle (I). When the solar collectors are unrolled you should see the word 'POOLSOLAR' on the bottom manifolds (M).

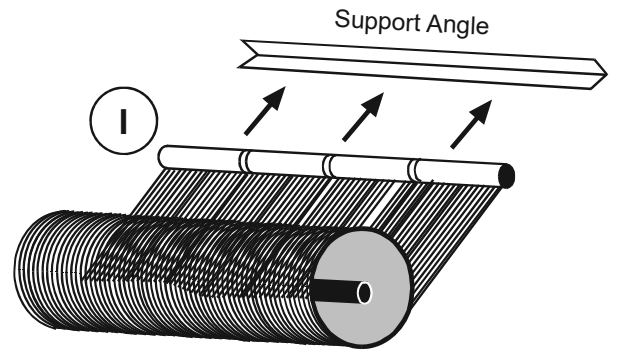
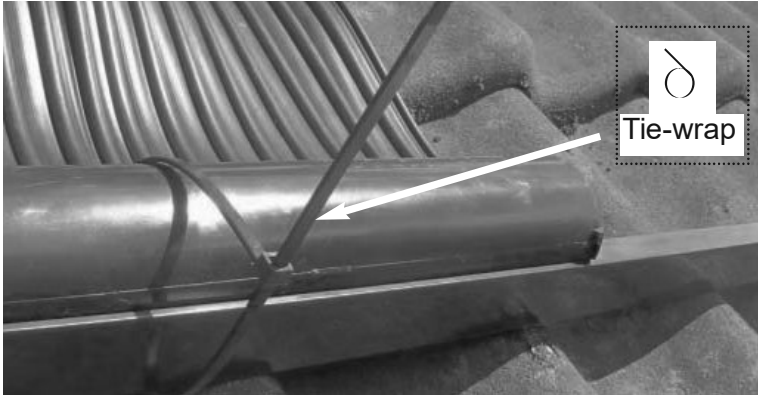

Using the electrical tie-wraps provided (J) connect the header to support angle every 66 cm.

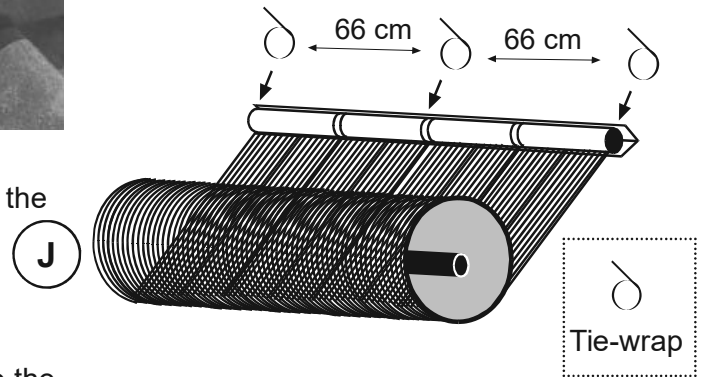

STEP 8 Apply an adhesive (K) bead every 50 cm to the roof structure and unroll the Poolsolar matting. It is also a good idea to apply adhesive down the very edge of the matting (L).

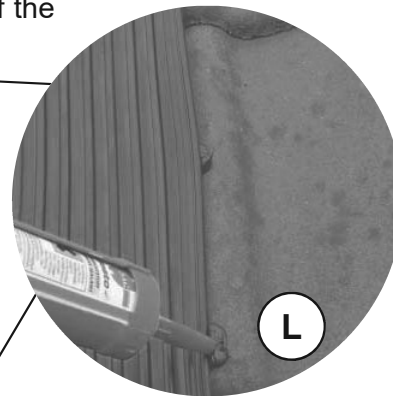
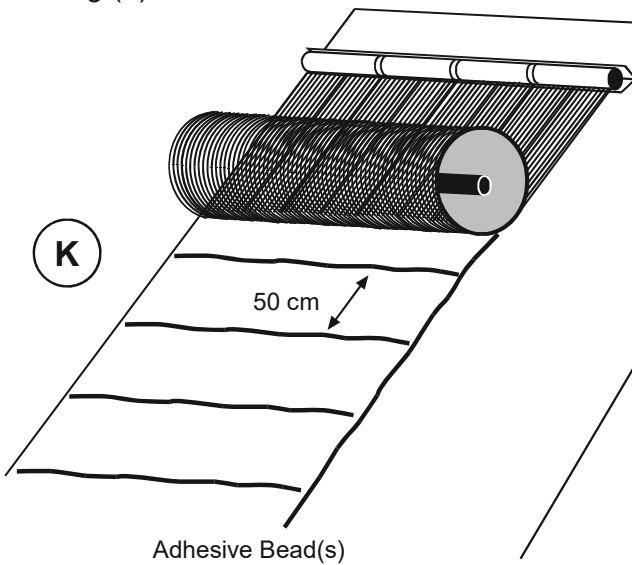

STEP 9 Apply a support (M) angle to roof structure to support the bottom headers. Secure headers to support angle with tie-wraps as per step 7.

STEP 10 Repeat above procedure to add additional Poolsolar Matting.

Proceed to Page 8 for plumbing connection.

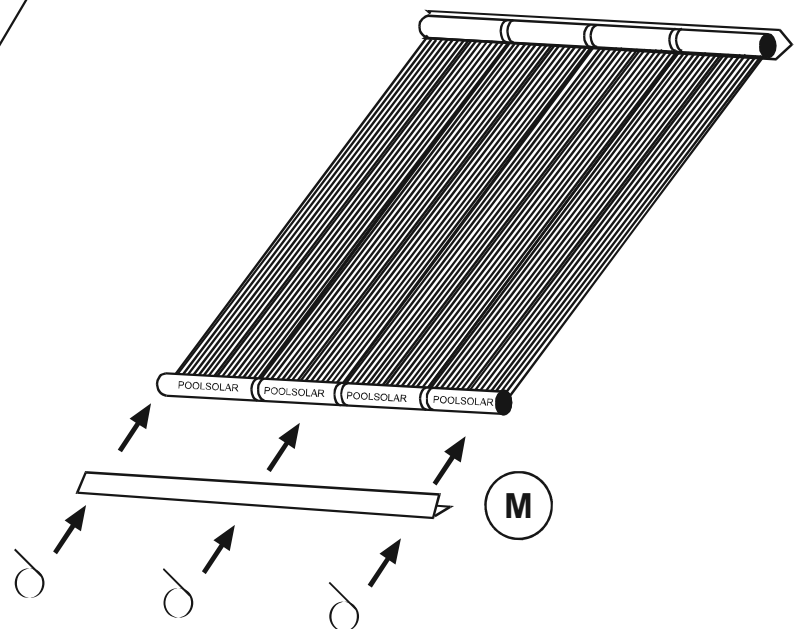

ALTERNATIVE FIXING METHOD FOR A TILED ROOF

In the event that you are unable to use an adhesive or support angle, nylon strapping (provided) can be used.

When the headers are are to be positioned on the roof, you will need to remove certain roof tiles to obtain a fixing onto the wood battens that support the roof tiles (O).



Fix 50 cm long nylon strips on the roof support batton every 66 cm as per step 7 on page 6. Afterwards put the roof tiles back in place so the nylon strips stick out 30 cm. Attach the nylon strips that stick out of the roof around the collector. Attach 2 tie-wraps to every nylon strip.

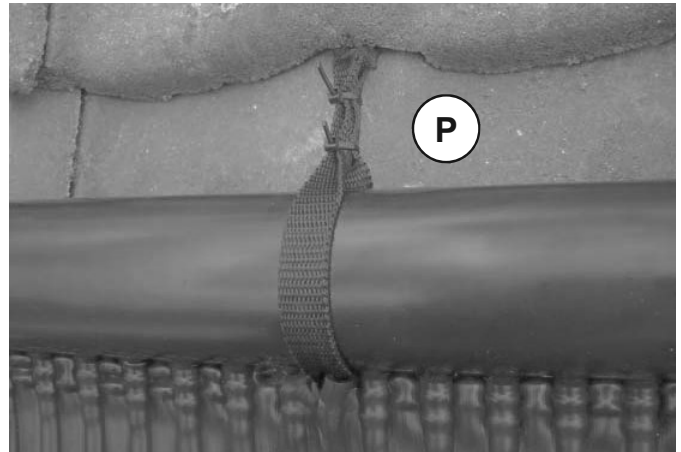

Nylon strapping can also be used (horizontally) across the width of matting to secure it to the roof structure (Q). Place straps 1 metre apart.

We highly recommend that adhesive is used where possible in addition to the nylon straps especially in high wind situations.

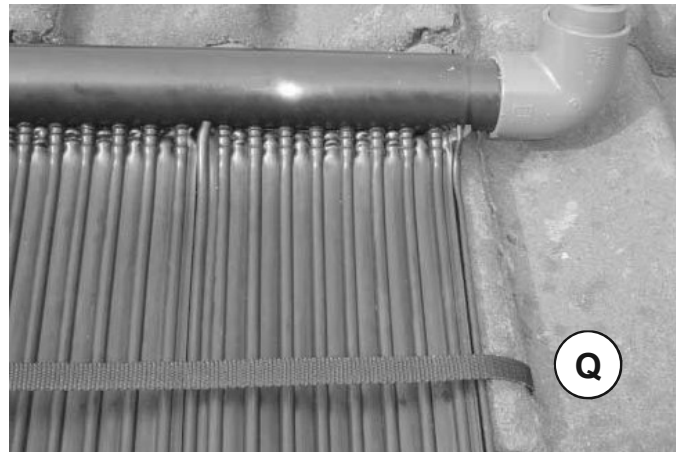

PLUMBING CONNECTION

Important Notes- Standard swimming pool plumbing in Europe is generally supplied in a metric dimension. However, in the UK all plumbing is supplied in an imperial measurement i.e. 1.5"

Poolsolar provide the correct plumbing adaptors that are enable you to connect to your existing pipework.

In addition, you will need to purchase a selection of ABS or PVC plumbing fittings (including a 3-way valve) and pipework from your pool dealer, together with the correct adhesive.

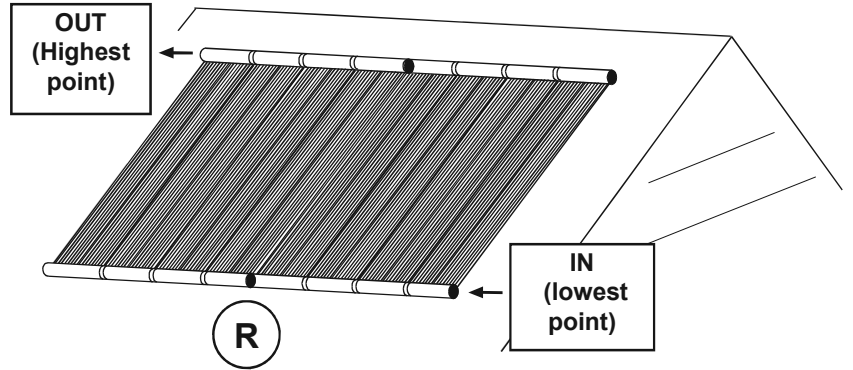

Do not be tempted to use domestic waste pipe, it has not been manufactured to accept the water pressure that is produced by your filtration. Never connect the Poolsolar to a mains water feed. Solar collectors have been designed to receive up to 1.5 bar. Pool filtration is typically +/- 1 bar.

The entire solar collector must be connected diagonally (R). The lowest point is where the water enters the collector, the highest point is where the water exits. In each Poolsolar kit you find extra connecting parts, so you can choose which method is suitable for your plumbing connection.

The extra supplied parts are made in ABS and can be glued with PVC-gluе. The headers (B) are made in PP (polypropylene) and CANNOT BE GLUED.

To connect pipework to the Poolsolar you need to apply the correct adaptors to each corner - C6/C8/C9/C13 see picture below (S).

IMPORTANT: The part of the adaptor(s) that is connected directly to the headers must be connected using a lubricant only (provided).

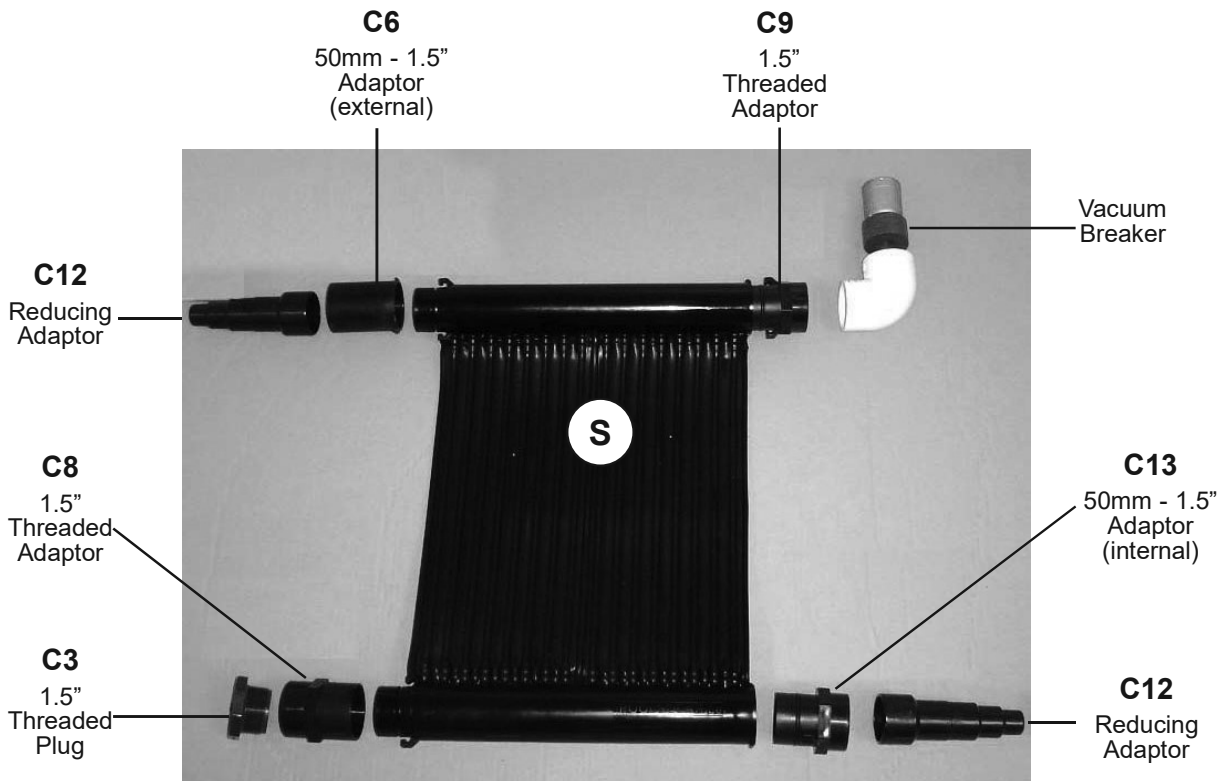

STEP 11 (T) Insert the correct plumbing adaptors to each corner C6-C8-C9-C13 (See page 8). Glue imperial reducing adaptors (C12) onto plumbing adaptor (C6 & C13) and cut to desired diameter. For all threaded fittings, apply PTFE. tape.

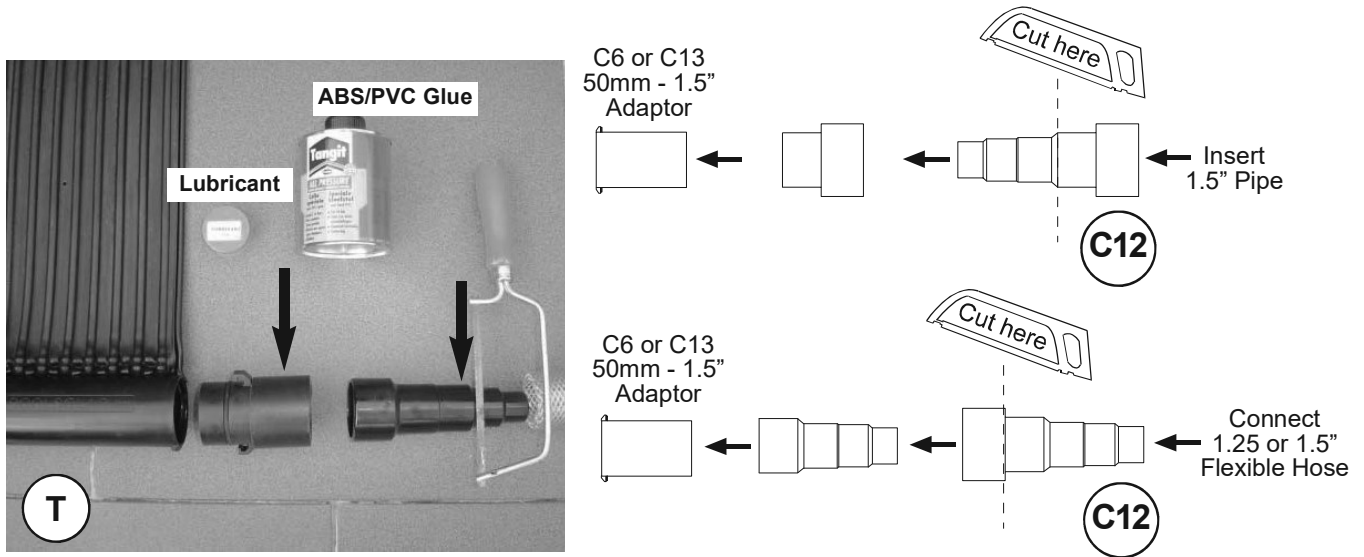

STEP 12 Connect ABS/PVC 1.5" plumbing to Poolsolar as per diagram below. You will need to install a 3-way valve, this will enable you to direct the water flow to the heater and back to the pool. A vacuum breaker will also be required on solar heating that is 4m or higher above ground level. Vacuum breakers are not required for low level installations. Once all of the plumbing connections have been made, proceed to step 13.

For other installation methods using an additional booster pump please go to page 13

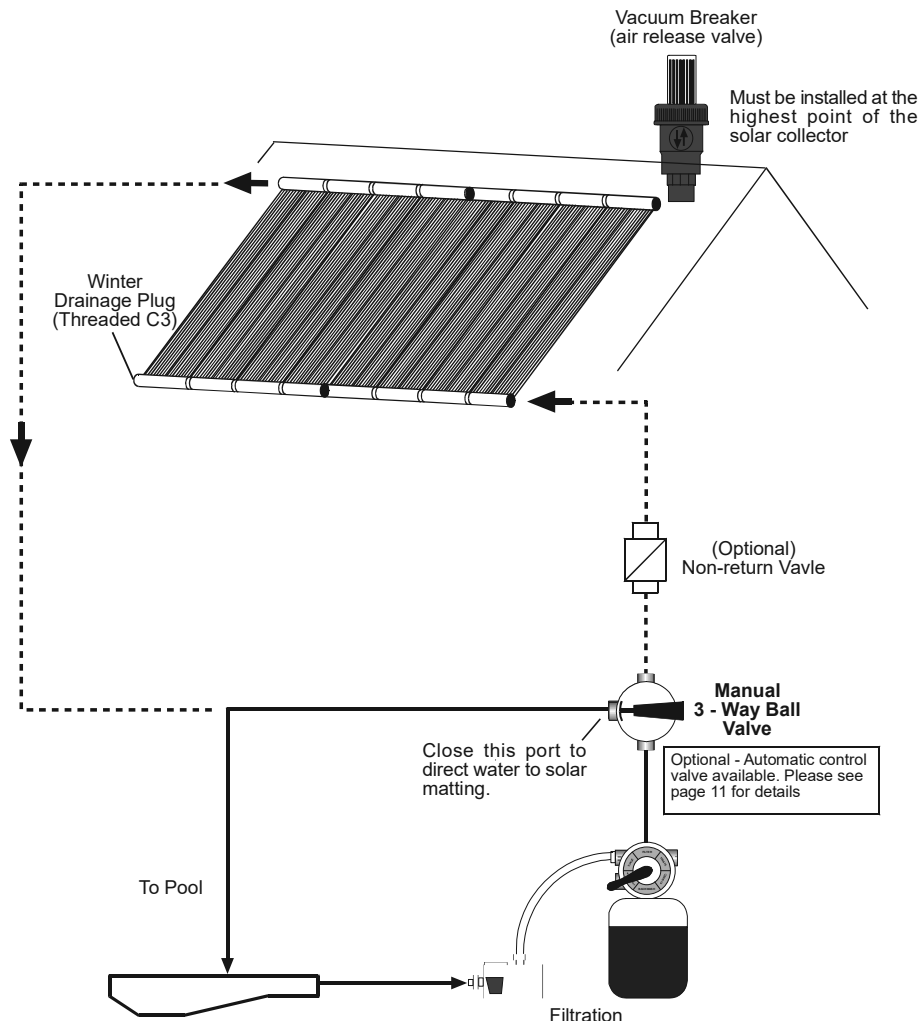

STEP 13 To operate the Poolsolar system the water flow needs to be redirected to the solar collector using a manually operated 3-way valve.

To direct water flow to solar collector :- Point the handle on the 3-way valve to close the port that directs the water back to the pool. The water flow will now pass through the solar collector and back to the pool.

To direct water flow to swimming pool only :- Point the handle to close the solar collector port when solar heating is not required. It is important that the water is not fed to the collector in cold periods of weather or at night as the solar collector will act like a giant radiator incurring great heat losses!

Your Poolsolar is now ready to start heating your pool.

Automatic 3-way valves are available to redirect the water flow automatically when cold periods arise. Please contact your pool dealer or go to page 11 for installation details.

3-Way Valve Operation

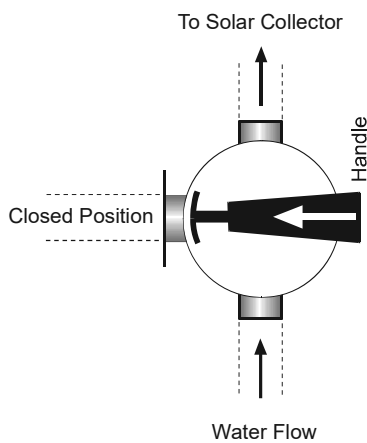

Water flow to Solar Collector

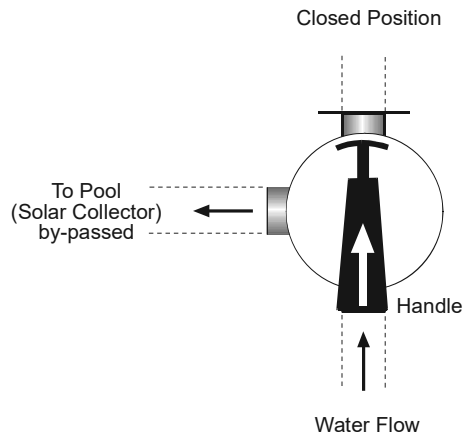

Water flow to pool, bypassing Solar Collector

GENERAL MAINTENANCE

Poolsolar is manufactured from a very durable, tough EPDM rubber that is long lasting and will provide many years of trouble free heating. There is little maintenance apart from hosing down the solar collector to clean it throughout the season.

In the event that you experience a leak in the solar collector a repair kit is provided. Go to page 15.

Winterisation

1. Solar collector must be drained for the winter period. Remove C3 1.5" thread plug for water removal (U).
2. Drain supply and return pipework.



SOLAR CONTROL SYSTEM (Automatic 3-Way Valve)

A Solar Control System will automatically turn the Poolsolar on and off depending on the weather conditions using an automatic 3-way valve.

When the sun is shining the valve will direct the water flow to the solar collector. When the temperature drops i.e. at night, the valve will direct the water flow back to the pool, bypassing the solar collector. Furthermore, it will stop the heating process when the desired temperature is reached.

Just as important, the valve will also prevent heated pool water from going to the collector when there is no sun i.e. cloudy/night conditions, thus preventing any heat loss.



To install the Solar Control System, please do the follow steps 1-45

STEP 1 Install Solar Controller (temperature adjustment) on a wall using the two screw holders on the back of the solar controller. Controller **MUST BE INSTALLED INDOORS**.



STEP 2 The 'Sun Temperature Sensor' should be placed on top of the solar collector header (manifold). Use a 'Tie-wrap' to secure into position. The 'Water Temperature Sensor' is already located within the motorised valve.



Note. Sun Sensor cable can be extended to a maximum distance of 25 metres. Use the same type cable i.e. 2 x core 0.34mm. Remove back plate on controller and insert desired cable length. Make water proof joint with the existing cable that was originally supplied.

Any electrical extension/adjustment should be carried out by a qualified electrician.

Please see diagram on page 13 for plumbing connection and position.

STEP 3 The 3- Way electronic motorised valve must be installed after the filter/pump (max bar 2.5).

DO NOT INSTALL MOTORISED VALVE OUTSIDE.

How does it work?

Your Solar controller has a 24 Volt DC output when solar heating is active.

Simply connect a two pair cable with your solar controller and connect the other end of the cable with the start input from the Electric Valve.

- When the output from you Solar controller is ON (solar heating is active) the Electric valve receives 24 Volt DC and will now turn, in this example Clockwise*.
- When the output from you Solar controller is OFF (solar heating is not active) the Electric valve turns to it rest position, in this example Counter Clockwise*.

*The direction of turning in above example can be changed using the direction switch (6).

Note: In this example we talked about a 24 Volt DC Solar co and DC. Please see diagram on page 12 for plumbing connection and position.

Overview External

- 1 Indicator LED (not visible)
- 2 Cable "start turning"
-Two wire cable
- 3 Cable entry "feedback"
- 4 Cable 12 VDC power supply
- 5 Water outlet port 1
- 6 Direction switch
- 7 Valve position indicator
- 8 Water inlet port
(not visible)
- 9 Water outlet port 2
- 10 Fuse 230 VAC 1 Amp Fast
(this type is suitable for the
internal 12 Volt DC Motor)

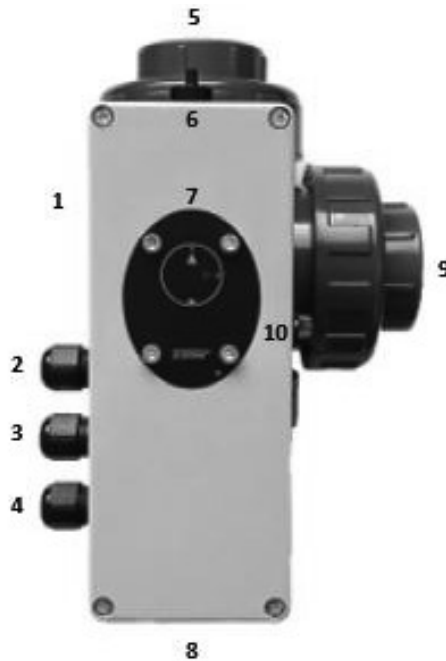

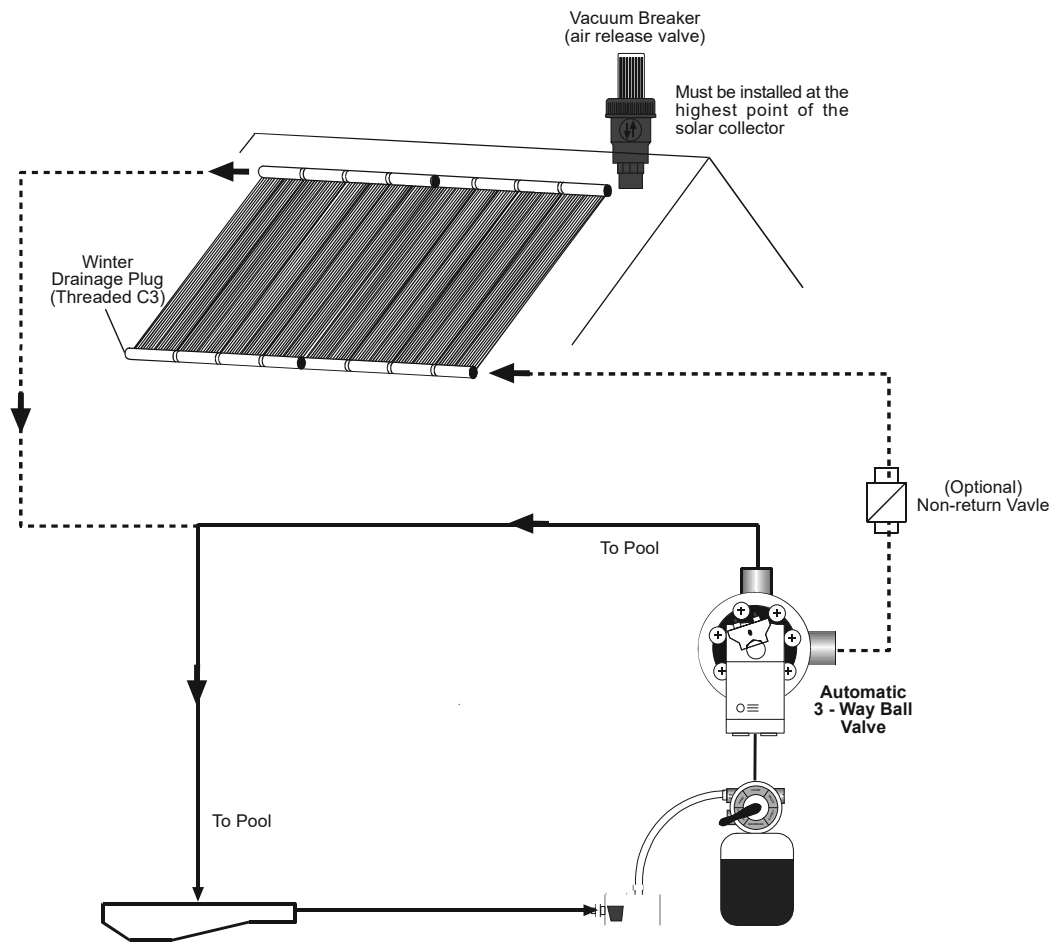

STEP 4 The transformer (3 pin plug) needs to be placed into a 230 V. indoor wall outlet. In the event that the motorised valve is not going to be used for long periods of time i.e. over the winter period, remove the transformer. INSTALLATION IS NOW COMPLETED.

Operation Use the plus or minus arrows for setting the desired temperature. After 5 seconds the desired temperature modus will stop and the actual pool water temperature will be displayed again. After a power failure the system will automatically set back the temperature on 25 degrees Celsius. When your desired temperature is different than 25 degrees Celsius you need to set your desired temperature again.

BOOSTER PUMP & SUN SENSOR - EXISTING POOL

In most situations your current filtration system has adequate pressure to supply water to the solar collector, normally up to 8m high. Your water flow pressure is very dependable on the power of the filtration pump, plumbing configuration etc.

If you are unsure about the necessity for a booster pump, try using your existing filtration first!

In the event that the desired place for your solar collector is on a high roof top in excess of 8 metres install a booster pump and sun sensor as per the diagram and instructions below.

The booster pump will require a water supply, we recommend utilising the Main Drain suction line. Please use the 'Y'-piece connections where indicated (prevents back pressure). Check with your pool dealer to make sure that you use the correct size booster pump.

Make sure the Electric Control System is only operational when the existing filtration is running!

For new pool installations we recommend that the booster pump is connected directly to the pool. Turn to page 14 for details.

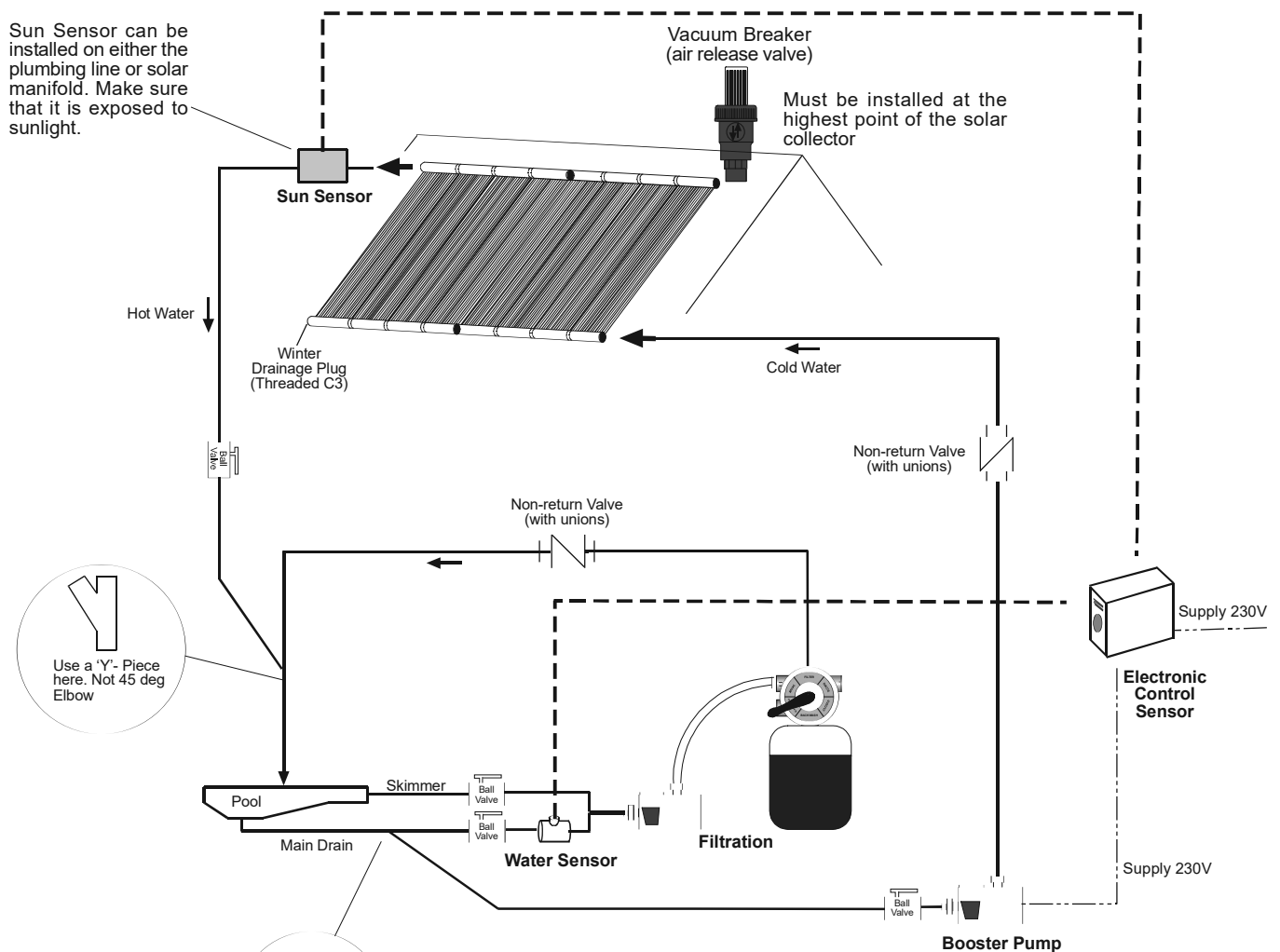

FILTRATION - MAXIMUM WORKING PRESSURE SHOULD NOT BE ABOVE 1.5 BAR (22 PSI)

Electronic Control Sensor monitors water and air temperature.

Water Sensor:- activates booster pump to increase water temperature to desired set point.

Sun Sensor:- allow booster pump to work only when the sun is heating solar collector.

BOOSTER PUMP & SUN SENSOR - NEW POOL CONSTRUCTION

In most situations your current filtration system has adequate pressure to supply water to the solar collector, normally up to 8m high. Your water flow pressure is very dependable on the horse power of the filtration pump, plumbing configuration etc.

If you are unsure about the necessity for a booster pump, try using your existing filtration first!

In the event that the desired place for your solar collector is on a roof top in excess of 8 metres high, install a booster pump and sun sensor as per the diagram and instructions below.

The booster pump will require a direct water supply to and from your pool. If you are in the process of building a swimming pool, we recommend installing the dedicated 1.5" pipework along the same pool fittings i.e. inlets etc.

Make sure the Electric Control System is only operational when the existing filtration is running!

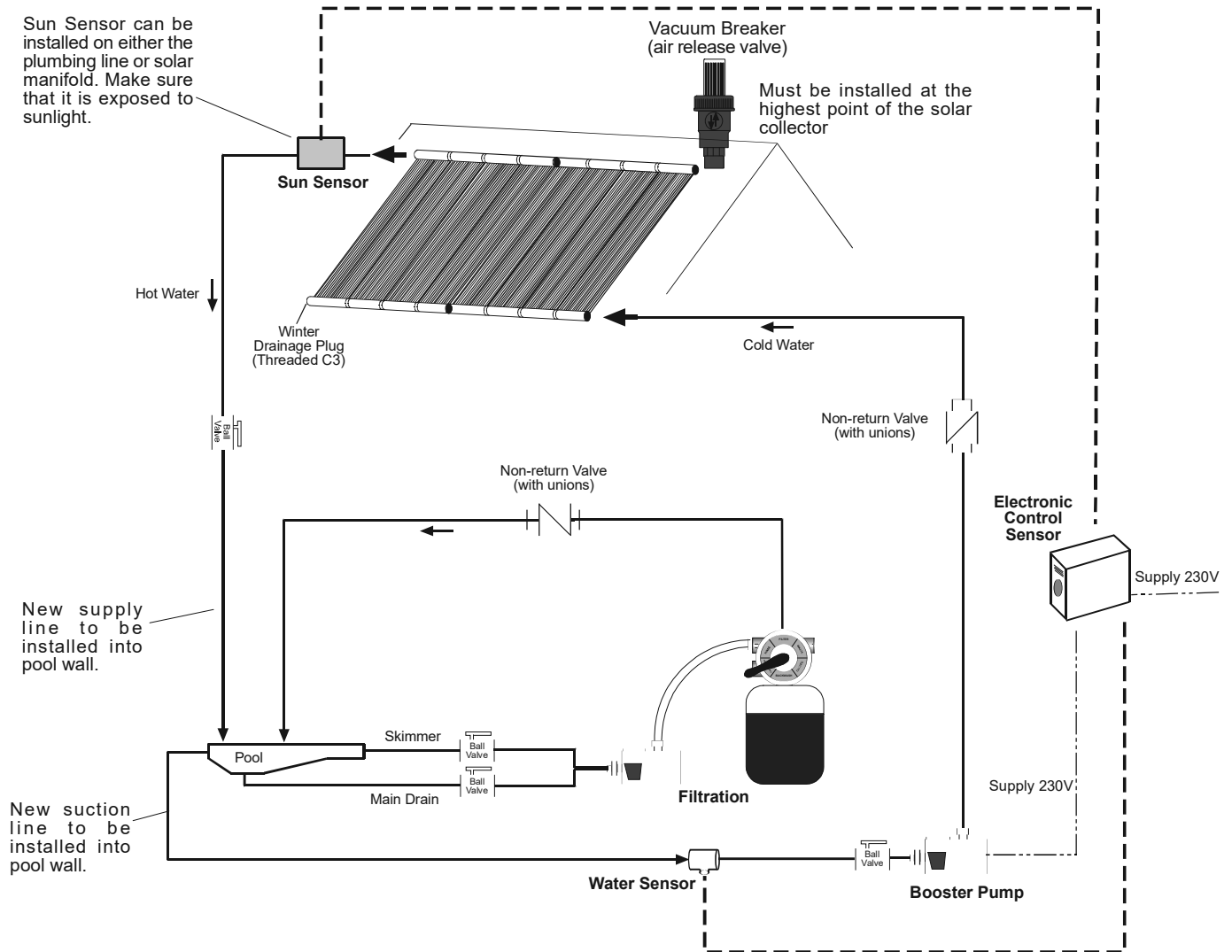

Electronic Control Sensor monitors water and air temperature.

Water Sensor:- activates booster pump to increase water temperature to desired set point.

Sun Sensor:- allow booster pump to work only when the sun is heating solar collector.

FILTRATION - MAXIMUM WORKING PRESSURE SHOULD NOT BE ABOVE 1.5 BAR (22 PSI)

REPAIRING POOLSOLAR

REPAIRING POOLSOLAR 'HEADER' (MANIFOLD NOZZLE).

You will need - Drill. 8 & 10mm Drill Bit, Scissors, Pliers, Plastic Repair Tube(s) (30mm x 6mm - provided), Lubricant (provided). Tie- Wraps (provided).

In the event a nozzle is damaged or breaks off the header, carry out the following repair procedure. Do not attempt to glue the nozzle(s) back into the header. The header is made from polypropylene and will not adhere.

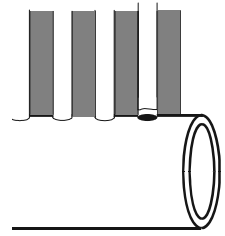

Step 1

The rubber that joins the tubes together to form the solar matting needs to be cut away either side of the tubing (approximately 10cm) using a pair of scissors. Be careful not to cut the tubing!

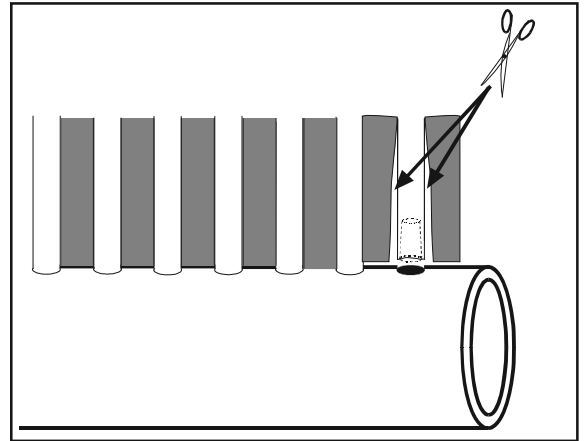

Step 2

Remove and discard broken or damaged nozzle from rubber tubing. Drill an 8mm hole into the existing nozzle hole (on header) to slightly enlarge it.

Tip - Once the 8mm hole has been drilled, lightly use a 10mm drill to form a slight counter-sink. This will enable the rubber tubing in step 4 to enter manifold much easier!

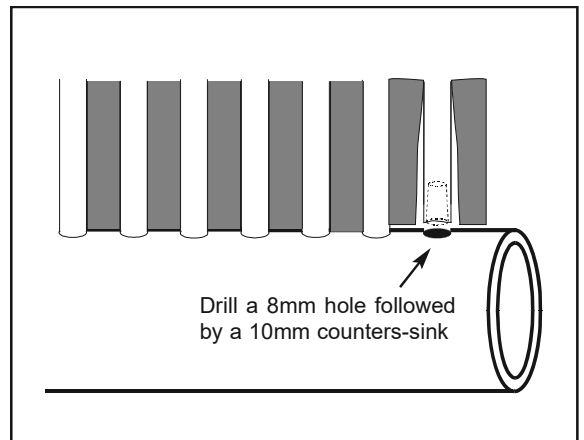

Step 3

Insert a plastic repair tube (30mm x 6mm - provided) using lubricant into rubber tubing. Leave 10mm of rubber protruding from the end of the plastic tube.

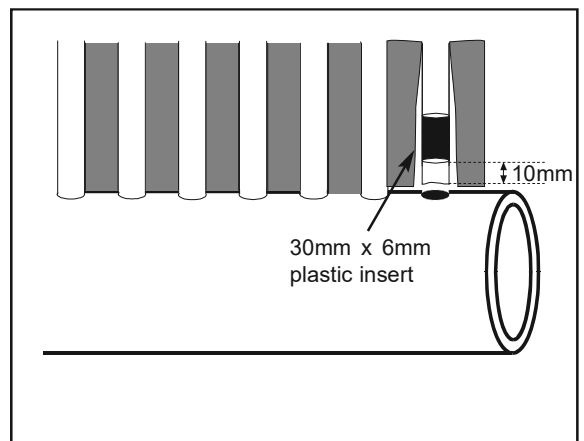

Step 4

Stretch the rubber tube with the inserted repair nozzle and force it into the pre-drilled hole (step 2). Use pliers and lubricant to do this.

The objective is to force the plastic repair tube down the rubber tubing and create a seal against the sides of the pre-drilled hole!

15mm of plastic repair tube should be inserted into the header.

The repair is now complete.

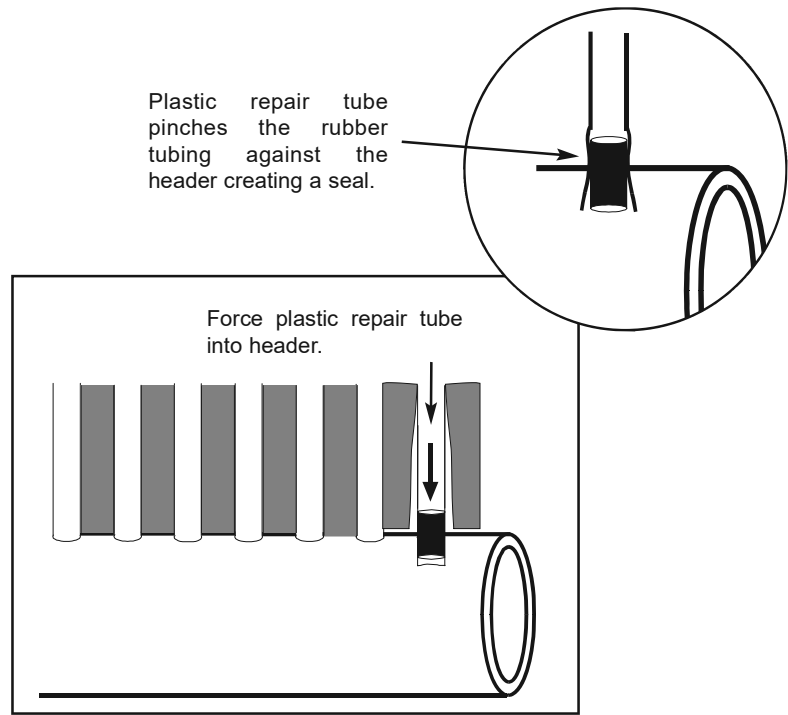

REPAIRING POOLSOLAR MATTING.

You will need - Scissors, Pliers, Plastic Repair Tube(s) (30mm x 6mm - provided), Lubricant (provided). Tie- Wraps (provided).

In the event a tube is punctured, carry out the following repair procedure. Do not attempt to glue the tubing back together. The tubing is made from EPDM and cannot be glued.

Step 1

The rubber that joins the tubes together to form the solar matting needs to be cut away either side of the tubing (approximately 2cm) using a pair of scissors. Be careful not to cut the tubing!

Step 2

Insert a plastic repair tube (30mm x 6mm - provided) using lubricant into rubber tubing.

Apply Tie- wrap to either sided of the plastic repair tube.

The repair is now complete.

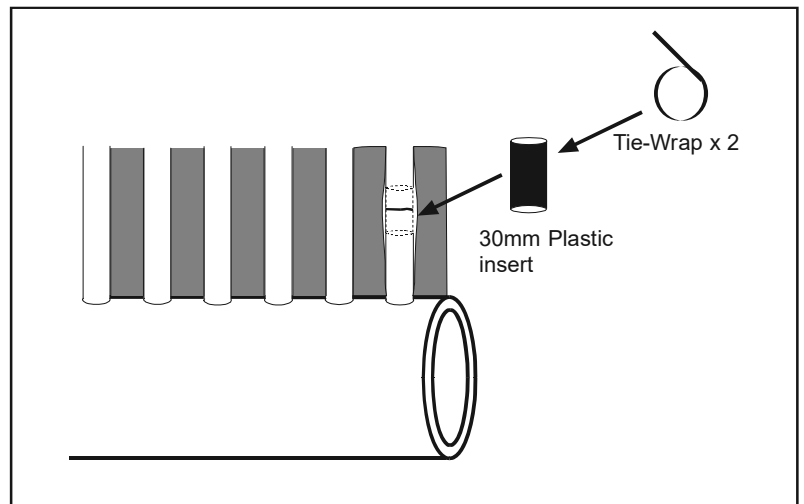

NOTES.

